



Dependable, cutting-edge technology

Start-stop and starter batteries



The future of mobility - all from a single source

We are your partner
for global
aftermarket solutions
and services

Our ambition as a global technology group, and one of the leading automotive suppliers and tire manufacturers, is to always have the best solution for our customer's needs. With a wide-ranging portfolio, the right technology, the top quality assured from an original equipment manufacturer, and services that provide real added value.

Make use of this extensive set of skills, and benefit from unique advantages for you and for your customers - for example with the new Continental start-stop and starter batteries.

The Continental Aftermarket range of services and product portfolio

- › **Battery program:** start-stop batteries with modern EFB and AGM technology, and starter batteries with reliable lead-acid technology
- › **Windshield wiper range:** durable, sturdy and easy to fit - AQUACTRL® windshield wipers for perfect visibility in all weathers
- › **Filter range:** the right filter for every application - reliable protection for injection systems, engines and passengers against contaminants, abrasion, ultrafine particles and moisture
- › **Brake systems:** high-grade brake components in OE quality - wear parts, hydraulic parts, brake fluids and electronic components
- › **Spare parts and repair parts:** perfectly fitting solutions in OEM quality - tire pressure monitoring systems (TPMS), windshield and headlight cleaning systems, sensors, fuel systems, control elements and motors, blower and fan systems
- › **Tires:** perfect control with summer tires, winter tires and all-weather tires for cars, SUVs and vans - the right tire for every use
- › **Mobility solutions:** innovative solutions for networked vehicles - for example in the field of remote diagnostics using the Remote Vehicle Data (RVD) platform, giving standardized access to vehicle data for a range of marques and models
- › **Workshop equipment:** test equipment and tools for brake servicing, ingenious solutions with diagnostic and service tools, plus efficient control of emissions
- › **Services:** all-round service for workshops - workshop concepts like ATE BrakeCenter, transfer of expertise by the Continental TrainingCenter, and support by a technical hotline and marketing measures
- › **Small series:** specific solutions for different requirements - from ABS units to instrumentation



More power: with our complete battery range

Whether it's start-stop batteries with advanced EFB or AGM technology, or starter batteries with dependable lead-acid technology - we can offer you a complete range of batteries from a single source, under the Continental brand.



Premium performance



High load capacity



Extreme temperatures



Everything you need: go with Continental for a comprehensive portfolio

The right technology for every vehicle - the wide range of products includes nine batteries for the future technology of start-stop, comprising six with EFB and three with AGM technology, plus ten starter batteries with lead-acid technology for vehicles without start-stop system.

The total of 19 different batteries covers in this segment 75 percent of current European vehicles. Every single battery is of original equipment quality and is made in Europe.



You can rely on it: a 2-year warranty

With our battery range, you benefit not only from a wider variety of products compared to other suppliers, but also from a twice-as-long warranty than the usual one of one year. Because we're confident about the quality of our products: thanks to advanced technologies, our batteries supply unrivaled power, with a cycle stability up to three times higher.

We can transmit that energy to your business too - with a full two-year warranty that you can pass on to your own customers.

Proven VDO quality - now under the Continental brand

To offer you a comprehensive range of batteries from a single source, we took the decision to combine our nine proven start-stop batteries of the VDO brand with ten starter batteries under the Continental brand. That way you benefit from a highly persuasive selection of Continental batteries that answer every need.

**Your
bonus:
a 2-year
warranty**

Unrivaled in capacity and duration

Start-stop batteries

Perfect for vehicles with start-stop system: our start-stop batteries are absolutely premium products distinguished by the latest high-power technology. Persuasive EFB or highly advanced AGM - these are technologies that always deliver top quality.

With its maintenance-free **Enhanced Flooded Battery (EFB)** with glass-fiber insert, Continental is offering a technology intended specifically for vehicles with start-stop system at the entry level - enabling low-resistance and high-speed charging and discharging.

The maintenance-free and long-life **Absorbent Glass Mat Battery (AGM)** with absorbent glass fleece (or "mat") is the best solution for all start-stop vehicles, including luxury models - and offers cycle stability up to three times higher than that of

conventional batteries. Thanks to the high charge capacity, AGM batteries can absorb large overvoltages from braking operations, making energy recuperation possible.

Best values

Better than our competitors: Continental start-stop batteries in a comparative test

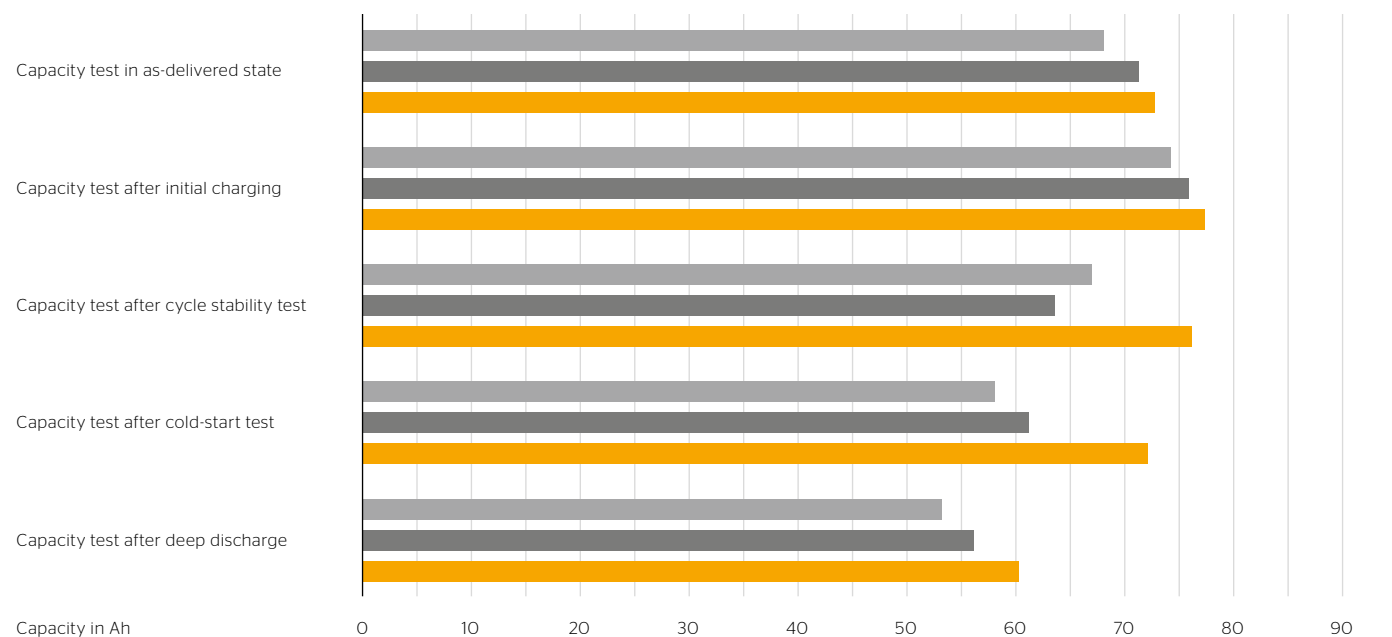

When **measuring the capacity of cycle stability, cold-start test and deep discharge**, the Continental AGM L4 batteries attain the **best values**.

Competitors' batteries
 Continental AGM L4

**EFB technology:
Battery design**

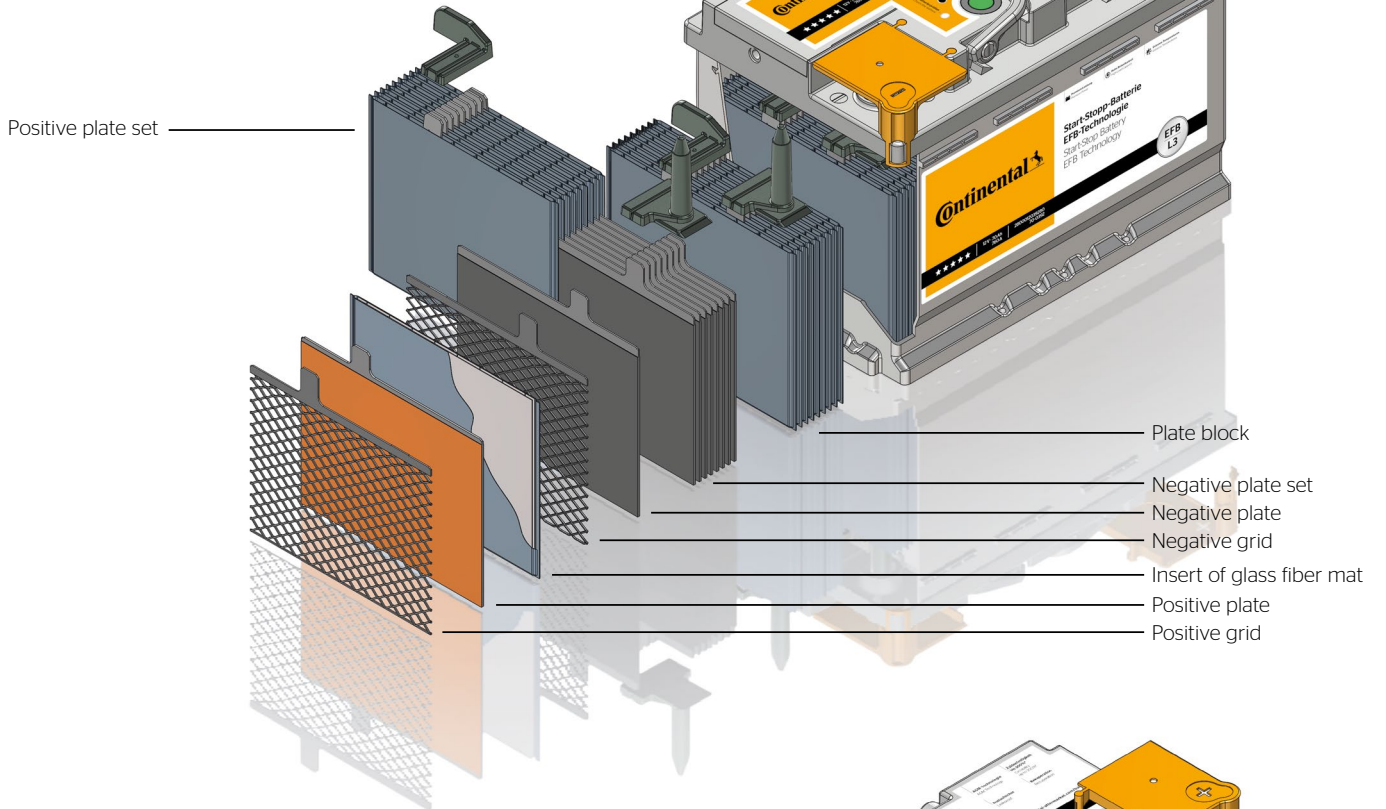

**AGM technology:
Battery design**

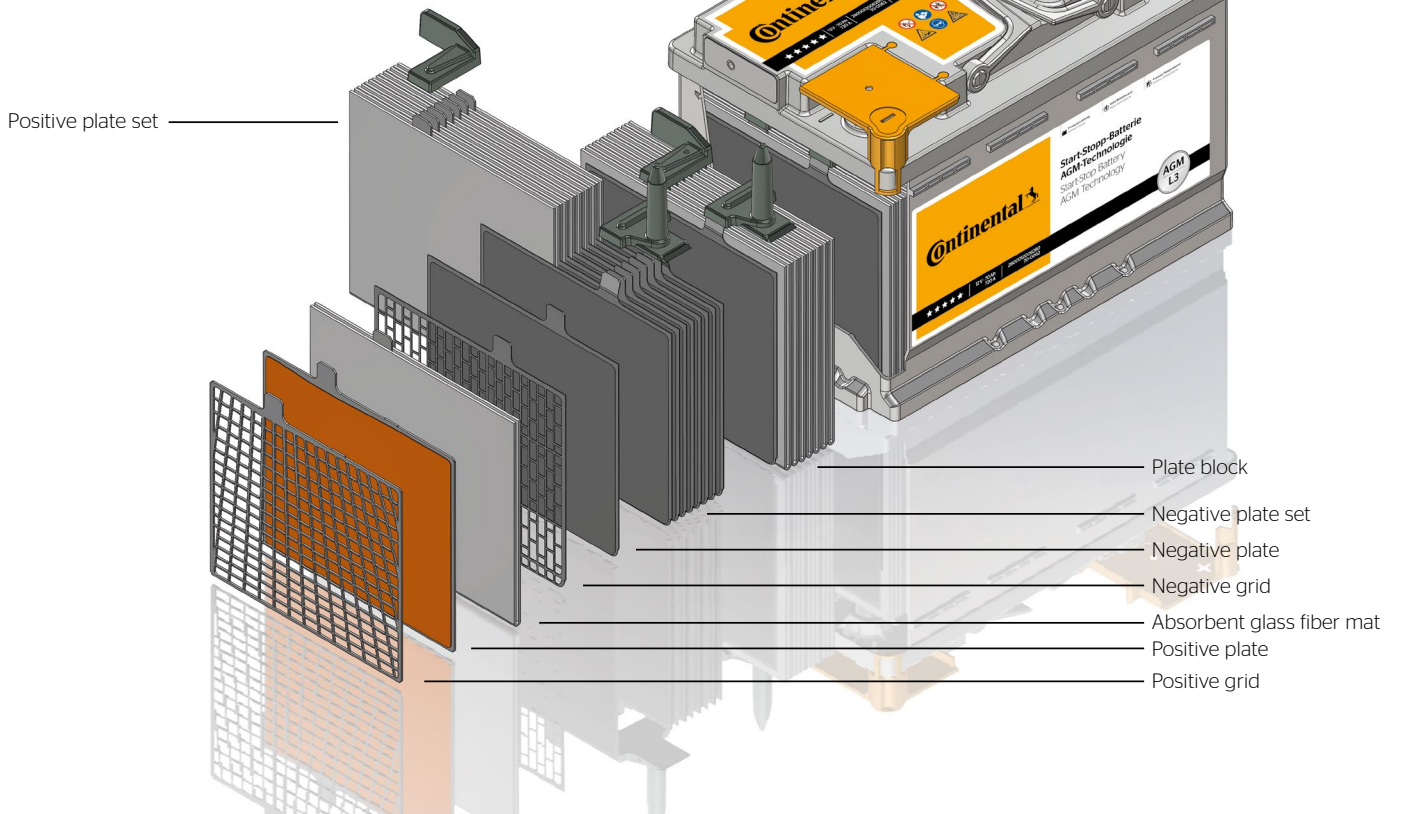



Advantages of EFB batteries

- › Perfect for vehicles with start-stop system at the entry level
- › For demanding climatic and weather conditions: 115 % cold-start performance (CCA)*
- › Long service life of at least twice as many cycles*
- › High deep-discharge capacity
- › 20 % lower energy consumption and greenhouse emissions*
- › Charge indicator light (Magic Eye)
- › Safety in extreme cases: 100 % leakproof
- › Maintenance-free - saves on labor and costs

Advantages of AGM batteries

- › Perfect for vehicles with start-stop system and braking energy recuperation
- › For demanding climatic and weather conditions: 135 % cold-start performance (CCA)*
- › Long service life of at least three times as many cycles*
- › Very high deep-discharge capacity
- › 20 % lower energy consumption and greenhouse emissions*
- › Safety in extreme cases: 100 % leakproof
- › Maintenance-free - saves on labor and costs

Technical information

Article number	Type	Box	Dimensions LxWxH [mm]	Weight [kg]	Voltage [V]	Capacity [Ah]	Cold test current [A]
2800012000280	EFB	L2	242 x 175 x 190	17.0	12	60	560
2800012004280	EFB	LB3	278 x 175 x 175	17.9	12	65	650
2800012001280	EFB	L3	278 x 175 x 190	20.0	12	70	650
2800012005280	EFB	LB4	315 x 175 x 175	20.0	12	75	730
2800012002280	EFB	L4	315 x 175 x 190	22.4	12	80	730
2800012003280	EFB	L5	353 x 175 x 190	25.1	12	95	800
2800012006280	AGM	L3	278 x 175 x 190	20.3	12	70	720
2800012007280	AGM	L4	315 x 175 x 190	23.0	12	80	800
2800012008280	AGM	L5	353 x 175 x 190	25.8	12	92	850

* compared to conventional batteries

Dependable and strong Starter batteries

New
to the
portfolio

The Continental **starter batteries** with conventional lead-acid technology are ideal for gasoline and diesel powered vehicles (HDI, TDI) without start-stop system. Thanks to their high capacity, they ensure at all times a sufficient voltage supply to the electrical and electronic systems inside the vehicle. They also boast an attractively low maintenance effort, high load capacity and long service life, and were designed for demanding climatic and weather conditions at extreme temperatures.

Advantages of starter batteries

- › Ideal for gasoline and diesel powered vehicles (HDI, TDI) without start-stop system
- › Safety in extreme cases: 100 % leakproof
- › Charge indicator light (Magic Eye)
- › Low maintenance - less labor and costs

Lead-acid technology: Battery design

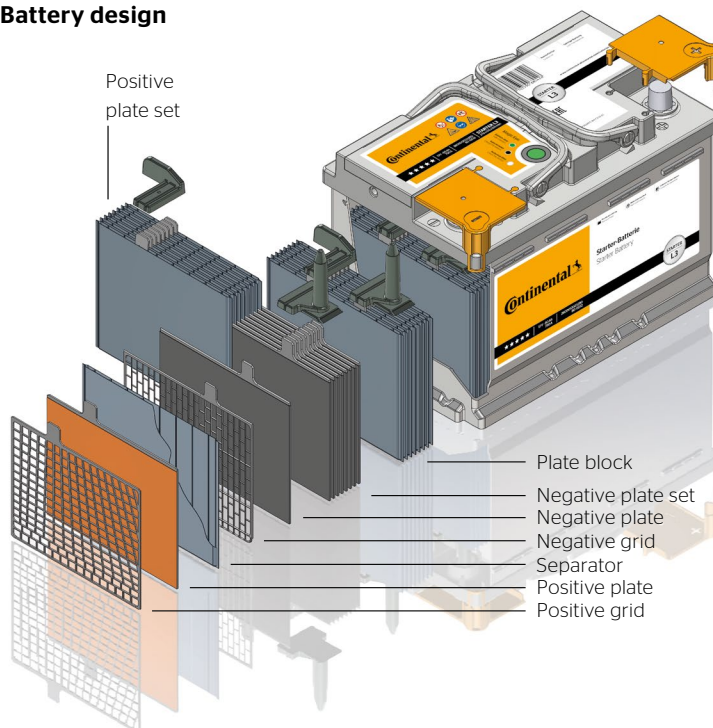

Technical information

Article number	Type	Box	Dimensions LxWxH [mm]	Weight [kg]	Voltage [V]	Capacity [Ah]	Cold test current [A]
2800012018280	Starter	LB1	207 x 175 x 175	11.8	12	50	500
2800012019280	Starter	L1	207 x 175 x 190	13.0	12	55	540
2800012020280	Starter	LB2	242 x 175 x 175	14.3	12	60	580
2800012021280	Starter	L2	242 x 175 x 190	15.5	12	65	640
2800012022280	Starter	LB3	278 x 175 x 175	16.4	12	70	680
2800012023280	Starter	L3	278 x 175 x 190	18.1	12	80	750
2800012024280	Starter	LB4	315 x 175 x 175	18.8	12	85	760
2800012025280	Starter	LB5	353 x 175 x 175	21.0	12	90	850
2800012026280	Starter	L5	353 x 175 x 190	23.2	12	100	900
2800012027280	Starter	L6	395 x 175 x 190	25.6	12	110	950





Your gain in energy: our service

Start-stop systems with integrated battery management require a lot of expertise when the battery is changed. You're always well equipped when backed by our extensive services and special training options.

Training, courses and products available

Changing batteries in sophisticated cars equipped with advanced start-stop systems and brake recuperation is increasingly becoming routine in workshops. So it's good to have the required specialized knowledge: the **training and courses offered by the Continental TrainingCenter** shows automotive professionals like you how replacement batteries are taught for battery energy management (BEM), as just one thing. What's more, our special diagnostics equipment like the **VDO Autodiagnos Check** makes your job easier. This handy service tester provides a rapid access to vehicle systems that works all by itself - and regardless of which manufacturer.

Put your trust in our overall concept and in the high product quality of our new technologies, and offer your customers a first-class service.



Find the right battery fast

You're looking for a certain product? Then use the search function on our website **www.continental-aftermarket.com** or our online catalog system **TecDoc**.

At **www.continental-aftermarket.com/batteries**, you can also obtain quickly, without any complications, all the information you need about the individual articles.



Always well advised - with great services



TrainingCenter



Product information & data management



Sales-promoting measures



Workshop concept



Go for Continental quality, with our comprehensive battery range:
www.continental-aftermarket.com/batteries



Continental Aftermarket & Services GmbH

Sodener Straße 9
65824 Schwalbach
Germany
T. +49 69 7603-0
info@continental-aftermarket.com
www.continental-aftermarket.com

Continental Reifen Deutschland GmbH

Büttnerstraße 25
30165 Hannover
Germany
T. +49 511 938-01
mail_service@conti.de
www.continental-reifen.de

Legal notice

The information in this brochure contains only general technical descriptions and performance characteristics, the applicability of which can depend on further factors in case of actual use. It is not meant or intended to be a specific guarantee of a particular quality or durability. An obligation to provide the respective characteristics shall only exist if expressly agreed in the terms of contract. We reserve the right to make changes in availability as well as technical changes.